



Transmission Connection and Planning Arrangements – Final determination

The AEMC has made a rule to amend those aspects of the National Electricity Rules that relate to the arrangements for transmission connections and planning, in response to a rule change request from the COAG Energy Council.

The final rule

The AEMC has made a final rule that sets out significant changes to the arrangements by which parties connect to the transmission network, and enhances the arrangements by which transmission businesses (TNSPs) plan their networks. The changes will provide for a comprehensive and coherent transmission connection and planning framework in the National Electricity Market (NEM).

The final rule is a more preferable final rule, but is consistent with the intention of the proposals put forward in the COAG Energy Council's rule change request, as well as the draft rule.

Transmission connection arrangements

The final rule provides more choice, control and certainty for connecting parties, while at the same time making it clear that the incumbent TNSPs are accountable for providing a safe, reliable and secure transmission network. Specifically, the final rule:

- better **defines** the assets and services required to facilitate a connection to the transmission network (described in attachment A)
- improves the **clarity** of the transmission connection process (summarised in attachment B)
- makes it clear and unambiguous that incumbent TNSPs have responsibility for the operation, maintenance and control of the shared transmission network, which promotes a **safe, reliable and secure network** for consumers
- introduces **competition** for the provision of services required to facilitate a connection to the transmission network, where this does not distort the accountability of the incumbent TNSP
- requires TNSPs to publish more and better **information** about how to connect to their network, and provide certain information to connecting parties on request
- strengthens the **principles** that underpin negotiations between connecting parties and incumbent TNSPs
- introduces a formal ability for either party to engage an **independent engineer** to provide advice on the technical aspects of a connection
- clarifies the process that applies to **disputes** about transmission connections.

Transmission planning arrangements

The final rule seeks to enhance the efficiency of the transmission planning arrangements and promote a more coordinated approach to transmission planning. Specifically, it:

- requires TNSPs to include certain additional **information** in their annual planning reports, including about network constraints, load forecasting methodologies and changes since the last report
- requires the AER to develop a guideline to support **consistency** across transmission annual planning reports
- requires TNSPs to undertake **joint planning** on investments in other transmission networks to deliver market and reliability benefits in their own network.

Application of the final rule in Victoria

The arrangements for transmission connection and planning are different in those jurisdictions where AEMO is authorised to exercise declared network functions, i.e. Victoria. In Victoria, the functions undertaken by TNSPs in other jurisdictions are split between AEMO and declared transmission system operators (DTSOs). AEMO is responsible for the provision of shared transmission services, procuring services from DTSOs (such as AusNet Services), who own and operate the shared network assets.

The AEMC concluded that the scope of the rule change request did not include consideration of the application of the final rule to AEMO's declared network functions. The transmission connection aspects of the final rule will therefore not apply in Victoria.

However, the COAG Energy Council asked the AEMC to provide advice on whether aspects of the rule change could be adopted in declared network jurisdictions with some modification. The final determination sets out the AEMC's view on the changes that could be made to the connections framework for declared network jurisdictions to be more consistent with those in the rest of the NEM under the final rule.

The transmission planning aspects of the final rule will apply in Victoria. AEMO is the jurisdictional planning body in Victoria as part of its declared network functions. The new obligations on TNSPs set out above will therefore apply to AEMO.

Background

The rule change request, submitted by the COAG Energy Council, was based on recommendations made by the AEMC in the Transmission Frameworks Review.

Connection aspects

The AEMC's findings in the *Transmission frameworks review* and stakeholder input on this rule change request highlighted a number of issues with the existing arrangements by which parties connect to the transmission network.

As a result of these issues, connection experiences and outcomes can be unpredictable, unnecessarily complex, lengthy and costly, and may vary across transmission network boundaries.

The final rule will:

- remove the scope for differing interpretations of the connections framework by connecting parties and TNSPs
- encourage TNSPs to provide connection services in a more cost effective, transparent, and timely manner
- give connecting parties a stronger ability to negotiate better connection outcomes with the incumbent TNSP.

The last decade has seen a rise in the number of parties connected to the transmission network, most notably new wind generators and gas facilities. With falls in technology costs and policy drivers such as the Australian Government's large-scale renewable energy target, an increasing number of new generators and loads are expected to connect to the transmission network. It is therefore important that the connection framework is fit for purpose.

Planning aspects

With respect to transmission planning, the Commission concluded that there were a number of measures that could be undertaken to enhance the efficiency of these arrangements and achieve a more coordinated and integrated approach to transmission planning.

For information contact:

Senior Director, **Suzanne Falvi** (02) 8296 7883

Director, **Victoria Mollard** (02) 8296 7872

Media: Communication Director, Prudence Anderson 0404 821 935 or (02) 8296 7817

23 May 2017

Attachment A: Transmission service classification under the final rule

Services	Shared transmission network	Identified user shared asset (part of shared transmission network)	Dedicated connection assets	Connecting party's facilities
Detailed design, construction and ownership	Primary TNSP (as a prescribed service)	If it meets contestability criteria: Connecting party (as a non-regulated transmission service)	Connecting party (as a non-regulated transmission service)	Connecting party, e.g. a generator (as a non-regulated transmission service)
Functional specification, cut-in works operation, maintenance and control		Primary TNSP (as a negotiated transmission service)		

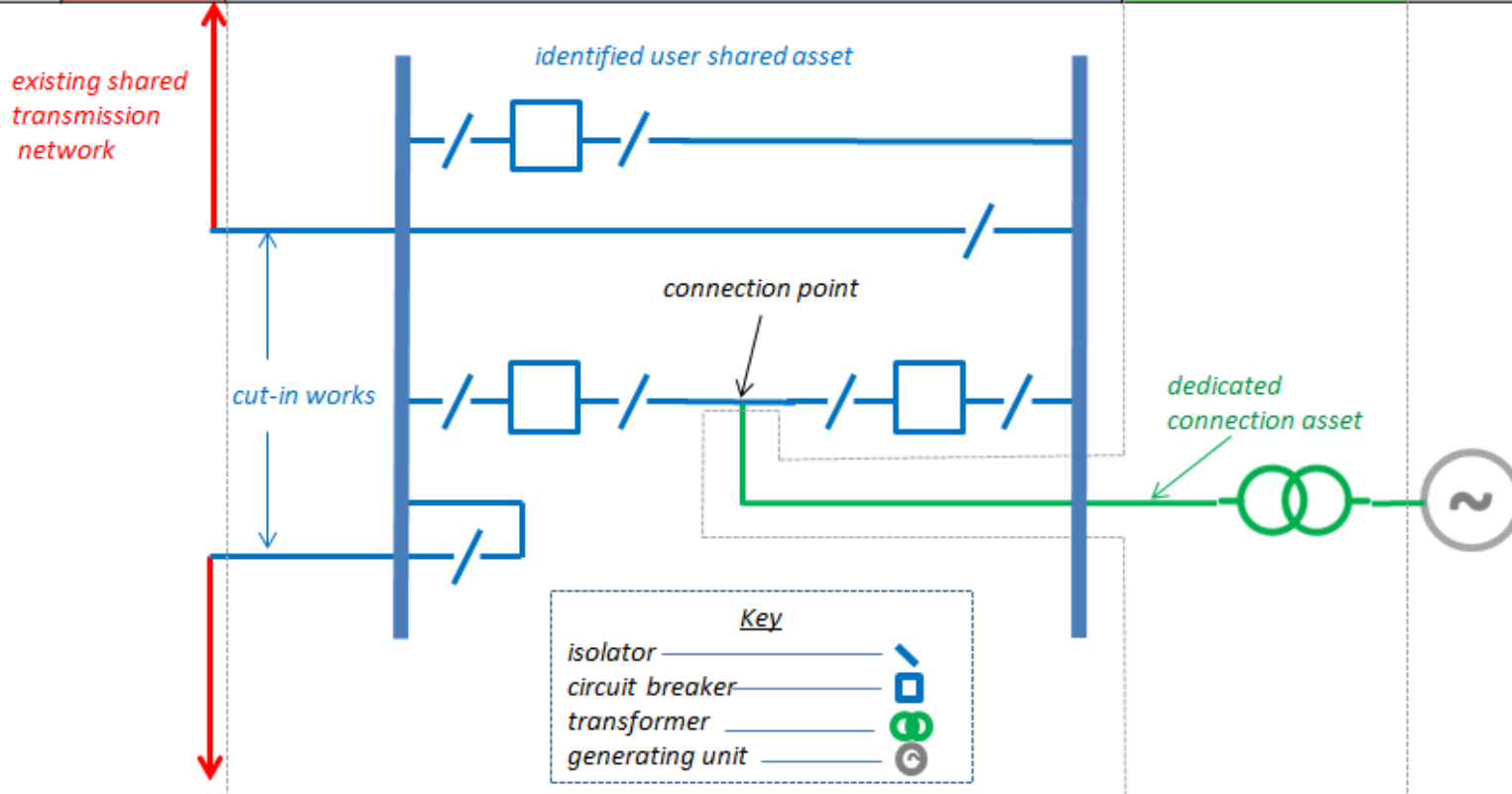

Attachment B: Summary of changes to the transmission connection process under the final rule

